

Roll No.

Total No. of Pages : 02

Total No. of Questions : 09

B.Tech.(Petroleum Refinery Engineering) (2013 Batch) (Sem.-6)

PROCESS INSTRUMENTATION & DYNAMIC CONTROL

Subject Code : BTPC-603

Paper ID : [74039]

Time : 3 Hrs.

Max. Marks : 60

INSTRUCTIONS TO CANDIDATES :

1. SECTION-A is COMPULSORY consisting of TEN questions carrying TWO marks each.
2. SECTION-B contains FIVE questions carrying FIVE marks each and students have to attempt any FOUR questions.
3. SECTION-C contains THREE questions carrying TEN marks each and students have to attempt any TWO questions.
4. Assume any missing data.

SECTION-A

1. Answer Briefly :

- a) What do you mean by ultimate value and what is rise time?
- b) What is Bode stability criterion?
- c) Define wet bulb temperature.
- d) Given the characteristic equation $s^4+3s^3+4s^2+5s+6=0$. How many roots have positive real parts?
- e) What are the general guidelines of a controller tuning?
- f) If $f(s) = \frac{(s-1)(s+1)}{s(s-3)(s+4)}$ find $f(t)$ at $t=0$ using the initial value theorem.
- g) What are the advantages of Pneumatic controllers?
- h) Differentiate closed loop and open loop control.
- i) Write the uses of following measurement (a) electrical and (b) thermal conductivity.
- j) What is the amplitude ratio and phase lag for first-order system with sinusoidal input?

SECTION-B

2. Write a short note on Ziegler – Nichols optimum controller setting.

3. The set point of the control system shown below is given a step change of 0.1 unit. Determine the offset.

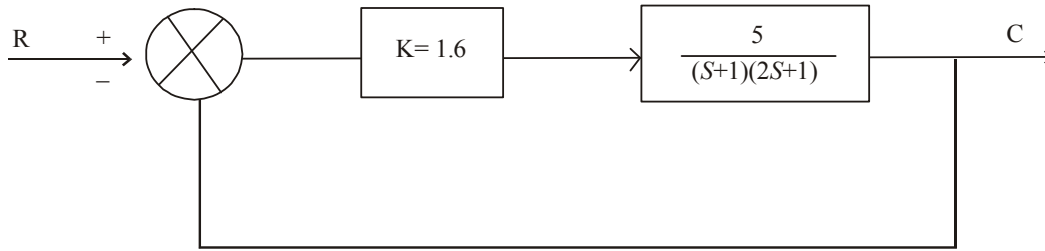

4. Discuss the advantages and disadvantages of P, PI, PD and PID controller.
 5. Consider a second order system with following transfer function

$$G(s) = \frac{Y(s)}{X(s)} = \frac{1}{s^2 + s + 1}$$

Introduce a step change of magnitude 1 into the system and find percent overshoot and decay ratio.

6. Explain Gain Margin and Phase margin with a neat sketch.

SECTION-C

7. Sketch the root locus for the following transfer function $1 + \frac{k}{(s+1)(2s+1)} = 0$

8. The two tank liquid level system shown in figure is operating at steady state when a step change is made in flow rate to tank 1. The transient response is critically damped, and it takes 1.0 min for change in level of the second tank to reach 50 % of the total change.

If the ratio of the cross-sectional areas of the tanks is $A_1/A_2 = 2$, calculate the ratio R_1/R_2 . Calculate the time constant for each tank. How long does it take for the change in level of the first tank to reach 90 % of the total change?

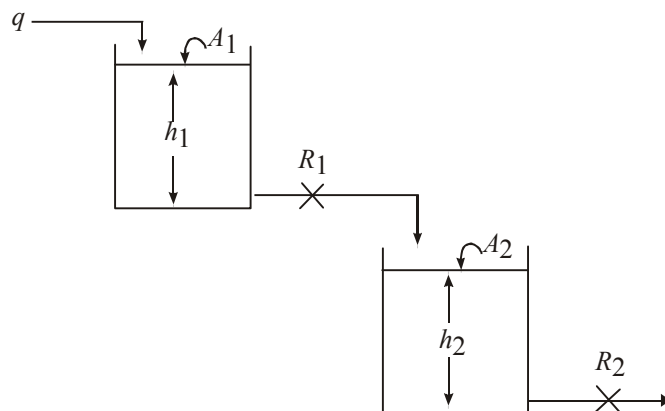

9. Discuss the principle of measurement and classification of Process Control instrument with respect to. i) Temperature ii) Pressure iii) Fluid flow.