

Roll No.

Total No. of Pages : 03

Total No. of Questions : 09

B.Tech.(ANE) (Sem.-5)
AIRCRAFT STRUCTURES-II
Subject Code : ANE-313
M.Code : 60522

Time : 3 Hrs.

Max. Marks : 60

INSTRUCTION TO CANDIDATES :

1. SECTION-A is COMPULSORY consisting of TEN questions carrying TWO marks each.
2. SECTION-B contains FIVE questions carrying FIVE marks each and students have to attempt any FOUR questions.
3. SECTION-C contains THREE questions carrying TEN marks each and students have to attempt any TWO questions.

SECTION-A

1. Write briefly :

- a) Write statement of energy approach for prediction of buckling of a column.
- b) What is dynamic approach for prediction of buckling of a column?
- c) Write boundary conditions for a simply supported plate.
- d) Explain application of Rayleigh Ritz method for prediction of buckling of a plate.
- e) Explain application of Galerkin's method for prediction of buckling of a plate.
- f) What do you understand by effective width of a plate?
- g) Differentiate between a pure tension field beam and a semi tension field beam.
- h) Write stiffness matrix of a single spring of stiffness 'k' placed along x axis.
- i) What is flexible method used for matrix analysis?
- j) What are advantages of finite element method over matrix method of analysis?

SECTION-B

- The pin-jointed column as shown below carries a compressive load P applied eccentrically at a distance e from the axis of the column. Determine the maximum bending moment in the column.

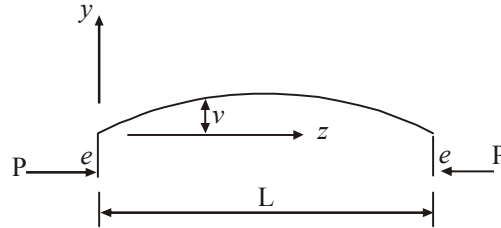

FIG.1

- A rectangular plate shown below is compressed by a uniformly distributed load N_x acting along two opposite ends which are simply supported. Obtain the buckling load of the plate by Rayleigh-Ritz method.

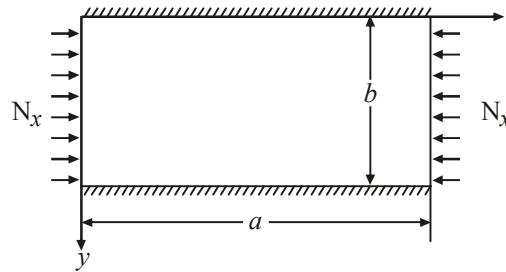

FIG.2

- Obtain the buckling load of a curved rectangular plate subjected to uniform compressive load N_r distributed around the edge of the plate.
- Determine the horizontal and vertical components of the deflection of node 2 of the pin-jointed frame work as shown below. The product AE is constant for all members.

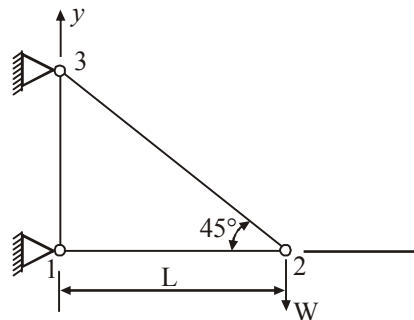

FIG.3

- A constant strain triangular element has corners 1(0,0), 2(4,0) and 3 (2,2) referred to a Cartesian Oxy axes system and is 1 unit thick. Obtain the expressions for displacements 'u' and 'v'.

SECTION-C

7. Develop stiffness matrix $[K_{ij}]$ for a uniform beam as shown below. The beam has flexural rigidity EI and length L . It is subjected to nodal forces $F_{y,i}$, $F_{y,j}$ and nodal moments M_i , M_j in the xy plane.

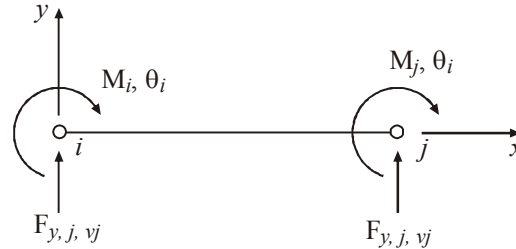

FIG.4

8. Consider a column of symmetrical I section as shown below. It is subjected to a compressive load P all along its flanges and it undergoes torsional buckling. Obtain the values of critical load and buckling loads due to flexure.

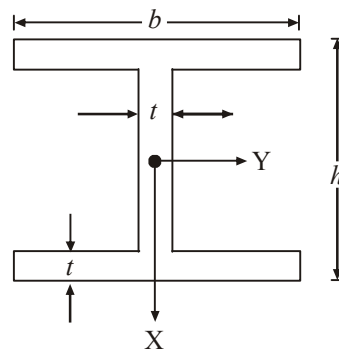

FIG.5

9. A diagonal tension field beam is tapered along its lengths as shown below. Calculate the loads in top and bottom flanges, σ_t and stiffener load P .

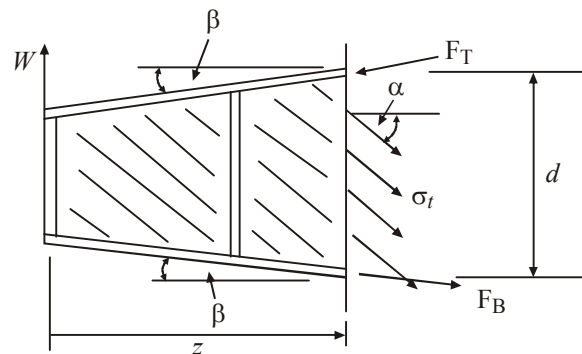

FIG.6

NOTE : Disclosure of Identity by writing Mobile No. or Making of passing request on any page of Answer Sheet will lead to UMC against the Student.